



*"The passion...
... for the precision"*



Sistema de
Gestión
ISO 9001:2015
www.tuv.com
ID 9105029570

LAIP S.A

*New products for
2020*

We are pleased to announce some of the new products introduced in our product range for the 2020 year



Sistema de
Gestión
ISO 9001:2015
www.tuv.com
ID 9105029570

LAIP S.A

2020



HSK –T TURNING SOLUTIONS



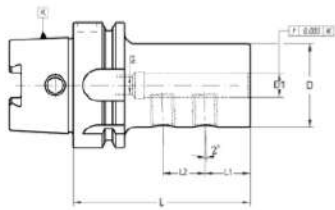

005 24 55 ... Laip

K	D1	L	D	L1	G	COD.	Availability Disponibilidad Verfügbarkeit	
63	8	65	28	65	M-8	005 24 55 04 08	■	301 01 03 08 10
63	10	70	35	70	M-8	005 24 55 04 10	■	301 01 03 08 12
63	12	70	42	70	M-8	005 24 55 04 12	■	301 01 03 08 12
63	16	75	48	75	M-10	005 24 55 04 16	■	301 01 03 10 16
63	20	75	52	75	M-10	005 24 55 04 20	■	301 01 03 10 16
63	25	83	65	83	M-12	005 24 55 04 25	■	301 01 03 12 16
63	32	87	62	87	M-12	005 24 55 04 32	■	301 01 03 12 16
63	40	87	62	87	M-12	005 24 55 04 40	■	301 01 03 16 12

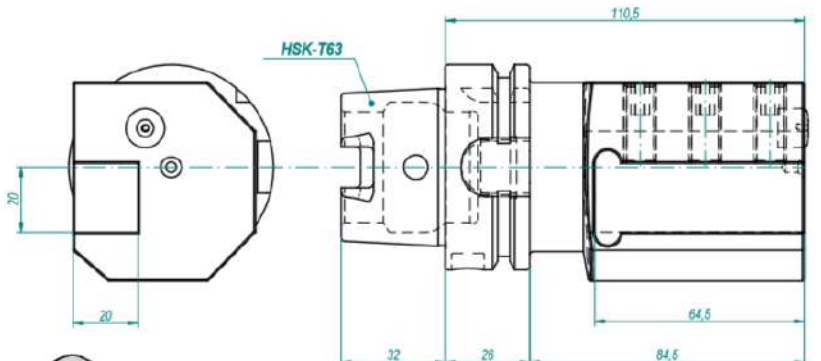

HSK-T63

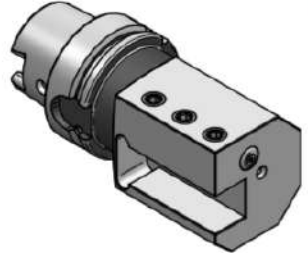
PTCUCHILLAS ICTM-63 20x20

1:1 Código: 00524600420

Turning solutions included in catalogue for multitask machining.

Grinding wheel toolholders



In multiple taper types, from HSK 25 to HSK 125, BT double contact, both for internal grinding machine or for vertical grinding machines and multitask machines.



We have increase our product range in POLIGONAL ISO 26623- LC6

Para herramientas con mango cilíndrico liso DIN 1835-A.
Für Werkzeuge mit zylindrischem Schaft nach DIN 1835-A.

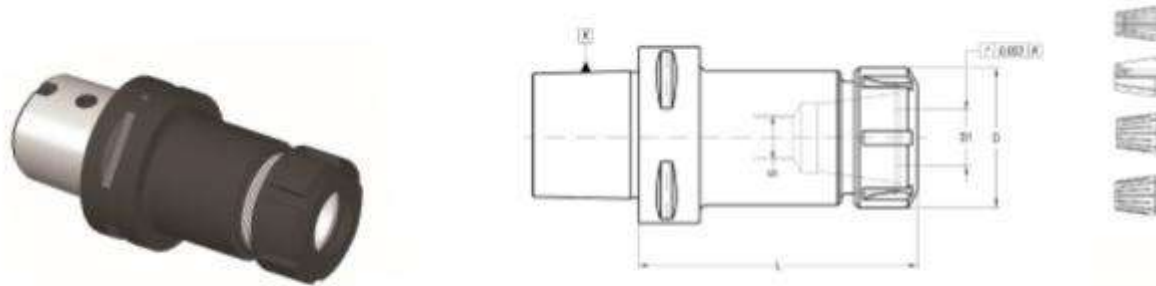

K	Size	D1	L	D	G	COD.
LC6	ER 16	0,5-10	100	28	-	004 10 06 04 03
LC6	ER 25	1-16	100	42	M - 16	004 10 06 04 05
LC6	ER 32	2 - 20	100	50	M - 16	004 10 06 04 06

ACCESSORIES INCLUDED
ACCESORIOS INCLUIDOS
ZUBEHÖR ENTHÄLT

Conventional
Convencional

Bearing shell nut
Cara con shell nut

Notch free
Libre

OPTIONAL ACCESSORIES
ACCESORIOS OPCIONALES
OPTIONALES ZUBEHÖR

RELATED ELEMENTS
ELEMENTOS RELACIONADOS
VERWANDTE ARTIKEL

ISO 26623 POLYGONAL SCHAFT

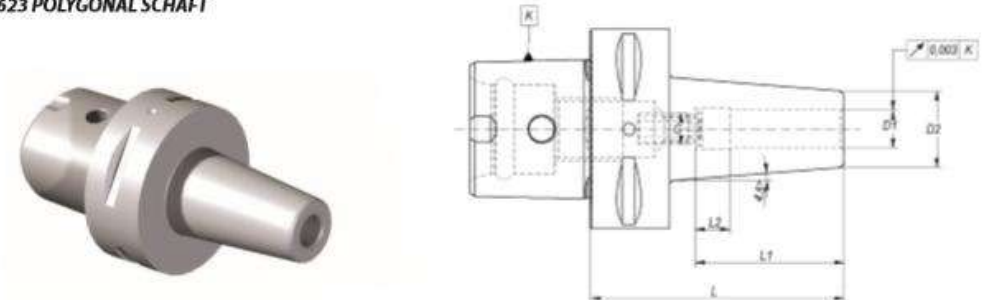

K	D1	D2	L	L1	L2	G	COD.	Availability Disponibilidad Verfügbarkeit	
LC6	3	12	80	20	-	-	012 10 12 14 03	■	-
LC6	4	14	80	20	-	-	012 10 12 14 04	■	-
LC6	5	16	80	25	-	-	012 10 12 14 05	■	-
LC6	6	21	80	36	10	M - 5	012 10 12 14 06	■	301 02 33 05 02
LC6	8	21	80	36	10	M - 6	012 10 12 14 08	■	301 02 33 06 02
LC6	10	24	80	41	10	M - 8	012 10 12 14 10	■	301 02 33 08 02
LC6	12	24	80	46	10	M - 0	012 10 12 14 12	■	301 02 33 10 02
LC6	14	27	85	46	10	M - 10	012 10 12 14 14	■	301 02 33 10 02
LC6	16	27	85	49	10	M - 12	012 10 12 14 16	■	301 02 33 12 02
LC6	18	33	85	49	10	M - 12	012 10 14 14 18	■	301 02 33 12 02
LC6	20	33	85	51	10	M - 16	012 10 12 14 20	■	301 02 33 16 02

More range in POLYGONAL LC6



TOOLHOLDER BLANKS PORTAHERRAMIENTAS SEMIACABADOS ROHLINGE

020 10

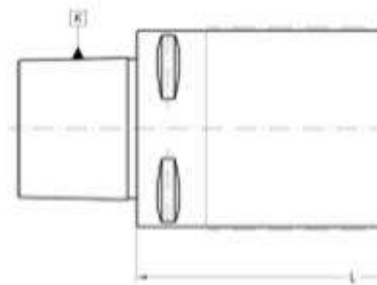

K	D	L	COD. Form A
LC6	63	180	020 10 02 0
LC6	110	120	020 10 02 0
LC6	120	180	020 10 02 0

HIGH POWER COLLET CHUCKS - HPTC - PORTAPINZAS DE ALTO PAR DE APRIETE - HPTC - HOCHLEISTUNGS-KRAFTSPANNFUTTER - HPTC -

004 10 55 ...

For tools with cylindrical straight shank.
Para herramientas con mango cilíndrico.
Für Werkzeuge mit zylindrischem Schaft.

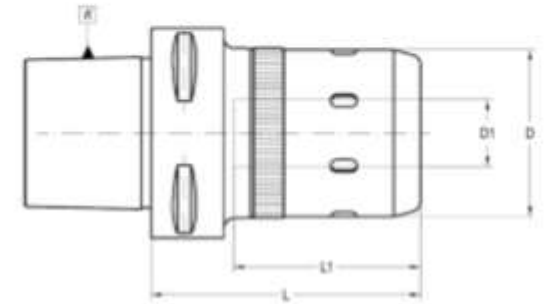

K	D1 max.	L	D	L1	COD.	Availability Disponibilidad Verfügbarkeit	
LC6	20	85	50	60	004 10 55 04 04	■	004 99 04 02 06
LC6	32	110	70	80	004 10 55 06 06	■	004 99 04 02 06

CHUCK BODY BALANCED TO
CUERPO EQUILIBRADO A
AUFNAHMEKÖRPER GEWUCHTET

LC 6

G 2,5 25.000 rpm

Page: 309

Use recommendations
Recomendaciones de uso
Anwendungsempfehlungen

New Rigid Tapping "Synkrotapping" range

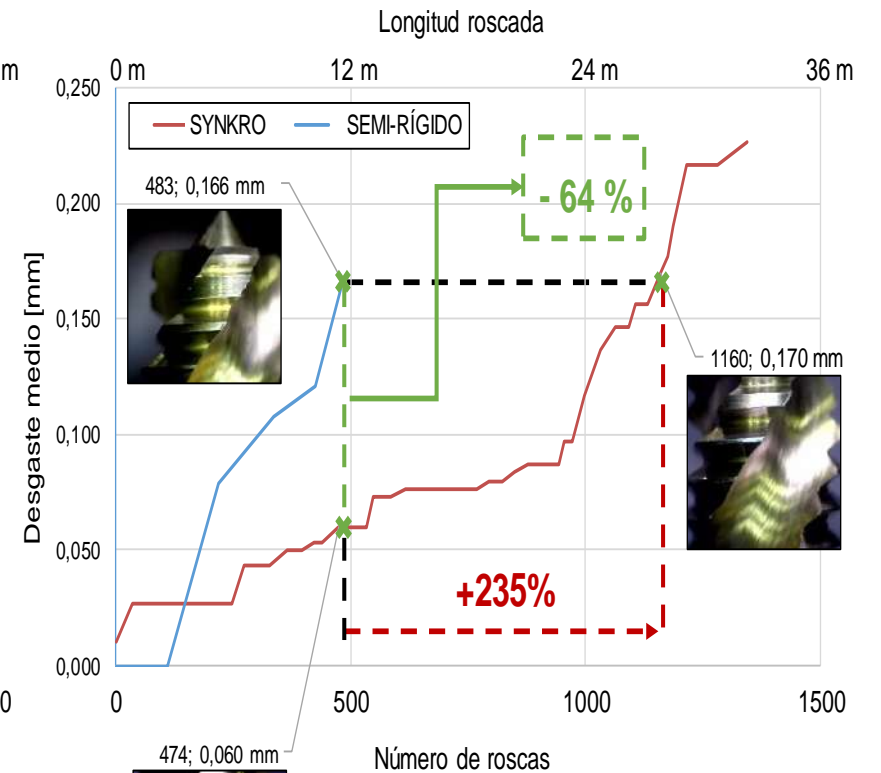
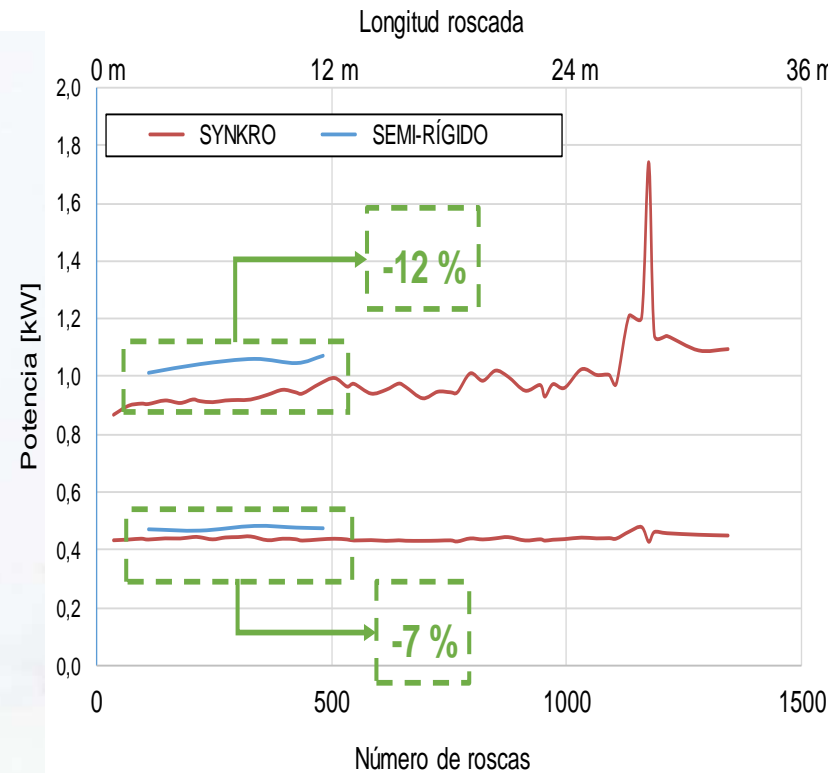

New Rigid Tapping “Synkrotapping” range

TAPPING CHUCKS FOR SYNCRONISATION FOR COLLETS DIN 6499 (ISO 15488) SYSTEM ER
PORTAHERRAMIENTAS SYNKRO PARA MACHOS DE ROSCAR DIN 6499 (ISO 15488) CON
PINZA ER DE CUADRADILLO.
GEWINDESCHNEIDFUTTER FÜR SPANNZANGEN DIN 6499 (ISO 15488) ER-SYSTEM

019 14 59 ...



AVAILABLE IN

HSK-A63 y HSK-A100
DIN 69871
BT

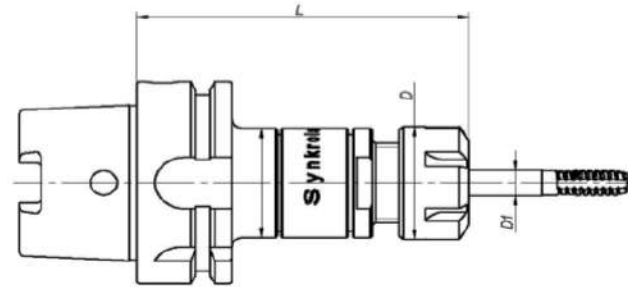

K	Size	D1	CAP	L	D	G	COD.	Availability Disponibilidad Verfügbarkeit
---	------	----	-----	---	---	---	------	---

More range in control gauge



For 3 axis and 5 axis verification in cnc machines

BALL-END RUNOUT TEST ARBORS BARRAS DE CONTROL DE BOLA PRÜFDORN MIT KUGEL

E

K	D	Ø	L	COD.
HSK 63	30	30	150	E020 14 05 14 30
HSK 100	30	30	150	E020 14 05 16 30

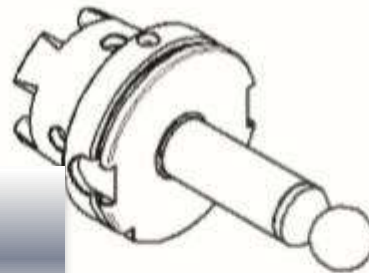

- *USED TO:
MEASURE THE RUNOUT ON A 5-AXIS HSK SPINDLE MACHINING CENTER.*
- *PARA CONTROLAR:
EL ALINEAMIENTO DEL HUSILLO EN MÁQUINAS DE 5 EJES.*
- *ZUM ÜBERPRÜFEN DES ROTATIONSZENTRUMPUNKTES UND FÜR
POSITIONSFEHLERKOMPENSATION VON SCHWENKKOPFSPINDELN.*

More range in BT 30 Double Contact Range

PORTAHERRAMIENTAS DE AMARRE POR CONTRACCIÓN TÉRMICA -ESTANDAR- SCHRUMPFUTTER

012 52 12 ...

Similar to DIN 69882-8
Similar to DIN 69882-8
Ähnlich DIN 69882-8

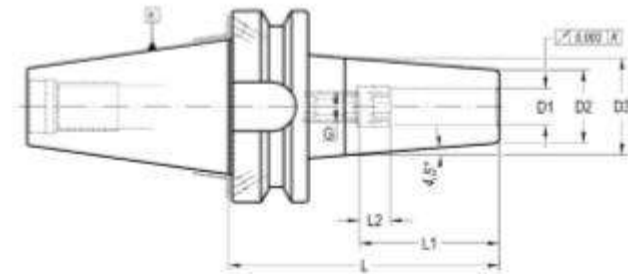

K	D1	L	D2	D3	L1	L2	G	COD. Form AD + B	Availability Disponibilidad Verfügbarkeit	
**30	3	90	12	18	-	-	-	012 52 12 11 03	■	-
**30	4	90	14	20	-	-	-	012 52 12 11 04	■	-
**30	5	90	16	22	-	-	-	012 52 12 11 05	■	-
**30	6	90	21	27	36	10	M-5	012 52 12 11 06	■	301 02 33 05 02
**30	8	90	21	27	36	10	M-6	012 52 12 11 08	■	301 02 33 06 02
**30	10	90	24	32	41	10	M-8	012 52 12 11 10	■	301 02 33 08 02
**30	12	90	24	32	46	10	M-10	012 52 12 11 12	■	301 02 33 10 02
**30	14	90	27	34	46	10	M-10	012 52 12 11 14	■	301 02 33 10 02
**30	16	90	27	34	49	10	M-12	012 52 12 11 16	■	301 02 33 12 02
**30	18	90	33	42	49	10	M-12	012 52 12 11 18	■	301 02 33 12 02
**30	20	90	33	42	51	10	M-16	012 52 12 11 20	■	301 02 33 16 02
**30	25	90	44	53	57	10	M-16	012 52 12 11 25	■	301 02 33 16 02

Precision cylindrical collets

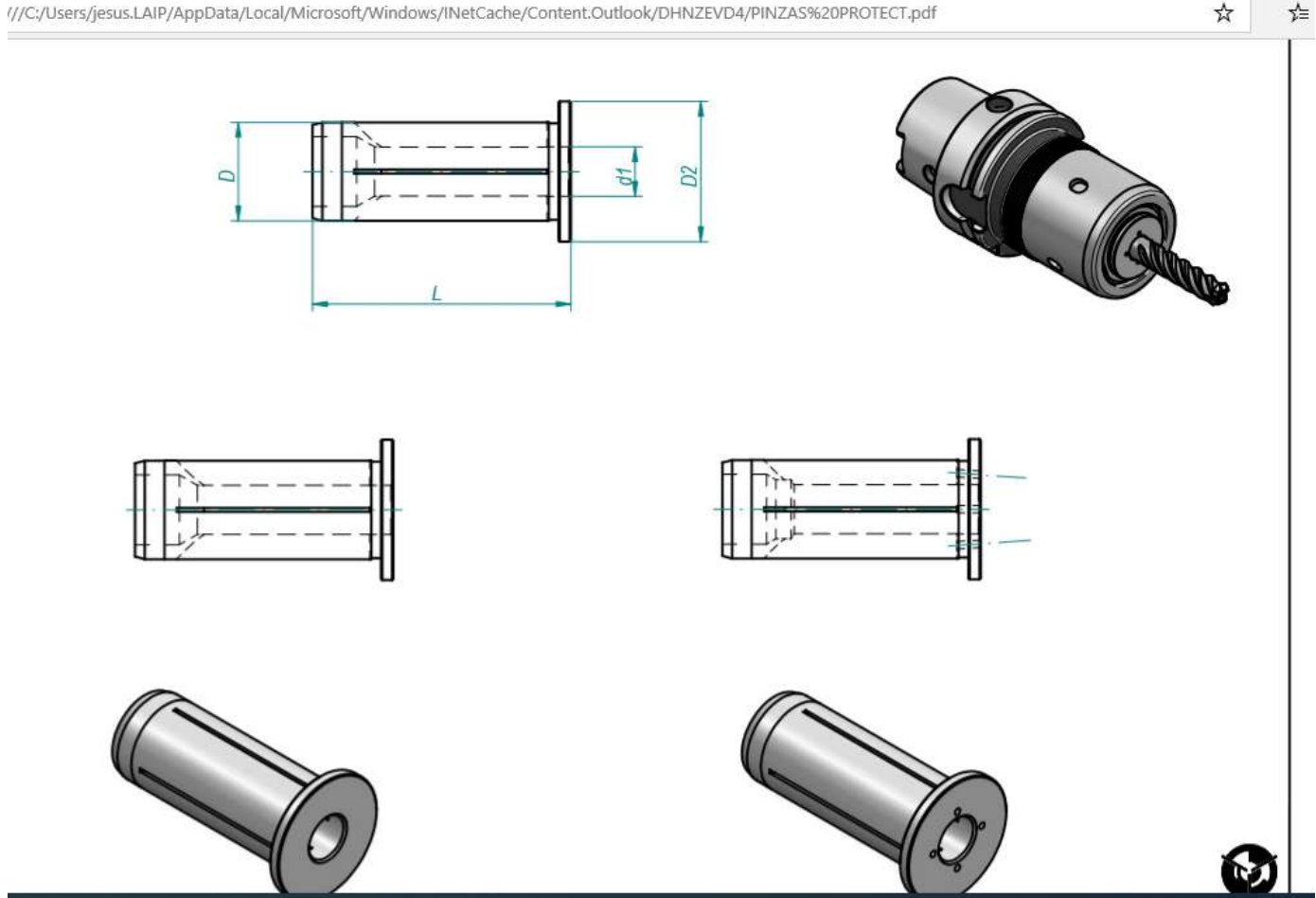

***Sealed collets
With or without coolant
through***

***Run out precision unde
3 microns***

Verification and reaconditioning of toolholders



Revision



Balancing



Verification



Certification



Repair

We guarantee the quality of the toolholders in that way your process can be more competitive with a better tooling performance.



LAIP S.A

Arzubia kalea, 2-Bº
Matiena

48220 ABADIANO
(BIZKAIA) – SPAIN



(+34) 94 621 76 92

ventas@laip.es

www.laip.es



Sistema de
Gestión
ISO 9001:2015

www.tuv.com
ID 9105029570