

**HIGH MEASURES' TOOLHOLDERS**

Due to the last years' investments and also because of the know-how accumulated in ours 60 years of experience, LAIP has supplied high measure grinding toolholder for a vertical grinding machine which used **HSK-A125** spindle.

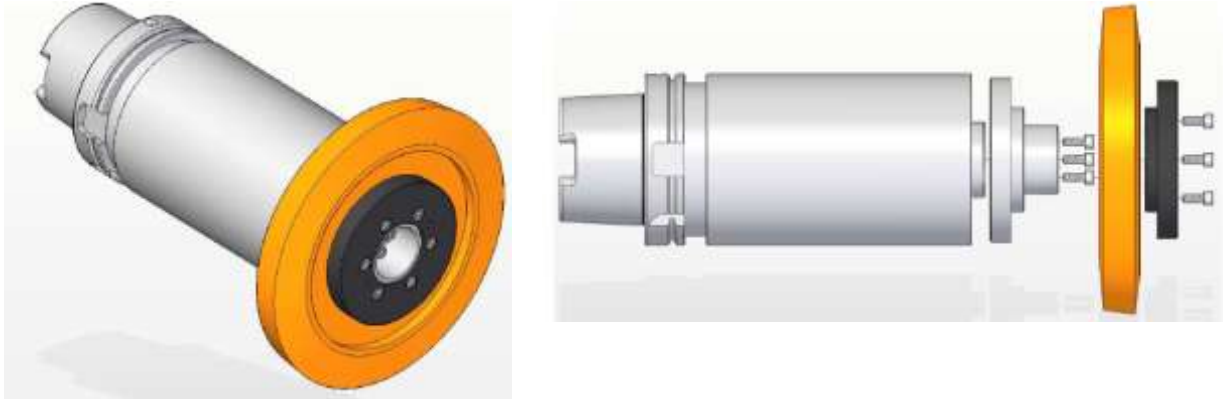

With the same holder system, we have available in the catalogue also products; Great Power Collet Chuck, Reducing Adapter to HSK, Blank toolholders, Modular System and a Test Arbor for control and measurement "in situ" of the spindle of the machining centers.



A) Great Power Collet Chuck



B) Adapter to HSK



C) Blank toolholder



D) Modular



E) Test arbor

We go on with the special requires of our customers to avoid the machining problems where the measure and the taper model is a highly important point to take into account such as double contact Din 69871-SK50 (check picture F) or DIN 69871-SK60 (check picture G).



F) Double contact Din-69871 SK50 Shrink fit chuck



G) DIN-69871 SK60 Shell End Mill Arbor